



**SuperSonicAire**

Assembly,  
Operation  
and  
Maintenance  
Manual

**PATENT PENDING**



## **INTRODUCTION**

You have selected the patented portable industrial cleaning and cooling fan. The **SuperSonicAire™** fans can be used for keeping your overhead structures and production equipment free of lint and dust buildup as well as cooling and destratification. Integrated Environmental Solutions (IES) designed the **SuperSonicAire™** to meet the most demanding needs of today's industrial plant with a minimum amount of maintenance and maximum amount of flexibility and reliability.

The **SuperSonicAire™** uses high velocity and high mass air flow to prevent the accumulation of fibers, dust or other undesirable waste in overhead structures and on plant process equipment. This is accomplished by preventing airborne particles and waste from accumulating on steel structures, pipes, ducts or process equipment.

The **SuperSonicAire™** can also be used to:

1. Prevent the accumulation of condensation on walls and overhead structures in rooms with high humidity.
2. De-stratify the buildup of hot air in the ceiling in the winter time (this will improve comfort and reduce energy costs)
3. Air circulation ventilation inside gymnasiums, factories, warehouses, airplane hangars, etc.
4. Eliminate spiders and spider webs.
5. Ventilation inside semi trailers while loading and unloading.
6. Drying non-porous items such as Dust Mats and Firemen Protective Clothing.

The application of the **SuperSonicAire™** to solve other types of problems has been many; so let IES discuss with you whatever need you have and explore the possibility of **SuperSonicAire™** being a part of the solution.

The SuperSonicAire™ requires 115v/1ph/60hz power. Simply plug it into a 115v wall outlet and you are ready to use your portable fan.

Because IES is always in the process of improving the **SuperSonicAire™**, we reserve the right to make change improvements in the design at anytime without notification.



## **SAFETY RULES**

***Warning: Failure to obey the instructions and safety rules in this manual may result in death or serious injury.***

### **Do Not Operate Unless:**

1. You learn and practice the principles of safe machine operation contained in this operator's manual.
  - a. Avoid hazardous situations. (Know and understand the safety rules before going on to the next section)
  - b. Always perform a pre-operation inspection.
  - c. Always perform function tests prior to use.
  - d. Inspect the workplace
  - e. Only use the machine as it was intended.
2. You read, understand and obey the manufacturer's instructions and safety rules—safety and operator's manuals and machine decals.
3. You read, understand and obey employer's safety rules and worksite regulations.
4. You read, understand and obey all applicable governmental regulations.
5. You are properly trained to safely operate the machine

### **Tip-Over Hazards**

1. Do not raise the fan unless the stand is on a firm, level surface.
2. Do not raise the fan unless all four legs are locked into the down position and each caster brake has been locked.
3. Do not raise the fan unless 25lb stability sandbags have been placed on all four legs.
4. Do not move machine while fan is in raised position.
5. Do not raise fan in strong or gusty winds.
6. Do not place ladders or scaffolds against any part of this machine.
7. Do not use machine on a moving or mobile surface or vehicle.

### **Electrocution Hazard**

1. Do not operate the machine near any overhead electrical current.
2. Keep away from the machine if it contacts energized power lines or becomes electrically charged.

### **Collision Hazards**

1. Do not lower the fan unless the area below is clear of personnel and obstructions.
2. Inspect the workplace to avoid overhead obstructions or possible hazards.
3. Do not move carts or other equipment around machine when it is in a raised position.
  - a. Use caution barriers if required to keep carts or other equipment from hitting machine.



## Pre-Operation Inspection

1. Be sure that the operator's manual is complete, legible and available for reference.
2. Be sure that all decals are legible and in place.
3. Visually inspect all machine components.
  - a. Twist plug is secure.
  - b. Power cable is clear of obstructions or catching on something
  - c. Compressed air is securely connected to control panel.
  - d. Electrical cables and pneumatic lines are not trip hazards on the floor.
  - e. All four legs are locked in down position and all casters are locked.
  - f. Fan easily raises and lowers with control switch on control panel.

## Workplace Inspection

**FUNDAMENTALS:** The workplace inspection helps the operator determine if the workplace is suitable for safe machine operation. It should be performed by the operator prior to moving the machine to the workplace. It is the operator's responsibility to read and remember the workplace hazards, then watch for and avoid them while moving, setting up and operating the machine.

Be aware of and avoid the following hazardous situations:

1. Drop-offs or holes
2. Bumps, floor obstructions or debris
3. Sloped surfaces
4. Unstable or slippery surfaces
5. Overhead obstructions and high voltage conductors
6. Hazardous locations
7. Inadequate surface support to withstand all load forces imposed by the machine
8. Wind and weather conditions
9. The presence of unauthorized personnel
10. Other possible unsafe conditions

## Operating Instructions

**FUNDAMENTALS:** If more than one operator is expected to use a machine at different times in the same work shift, each operator is expected to follow all safety rules and instructions in the operator's manual. That means every new operator should perform a pre-operation inspection, function tests and a workplace inspection before using the machine.

**Lift Instructions:** When new, the lift may be stiff due to tight seals and packings. The lift will function smoother after use. The lift is heavily lubricated during manufacture to assure long lasting and smooth performance. Occasionally, excess oil may leak out of the quick disconnect plug at the base of the lift assembly.

## Maintenance Schedule

**Daily:** Inspect and if necessary tighten all components and fasteners (nuts, bolts, screws, fittings, hoses, tubing, etc.) Inspect all (4) legs to be sure they are locked in down position. Inspect casters and caster brakes for proper operation.

**Monthly:** Visually inspect the felt wipers on the lift. Remove debris and clean as necessary.



## **ASSEMBLY INSTRUCTIONS**

Each SuperSonicAire (SSA) is shipped in a separate container and requires some assembly.

Please follow the steps below for a successful assembly and usage of your SSA fan.

### **UNPACKING AND ASSEMBLY**

1. Remove shipping straps holding the SSA shipping box to the wood pallet.
2. Remove top smaller box which supports and protects the pneumatic actuated support stand.
3. Open top of bottom larger box and carefully remove the parts packed inside the box.
  - a. Remove control panel support from top of lower box.
  - b. Remove control panel from lower box.
  - c. Remove fan inlet guard from lower box.
  - d. Remove stability sand bags from lower box.
4. The SSA is shipped upside down and must be rotated 180 degrees. It is best to have at least (3) strong healthy people to remove SSA from box and stand upright. The fan weighs 150lbs and the stand weights 40lbs.
  - a. Carefully lay down (over) SSA horizontally on the floor.
  - b. Carefully pull fan out of larger box.
    - i. Set fan motor on floor so that you do not scratch the fan support yoke.
  - c. Lower (3) out of the (4) support legs until they lock into place.
    - i. Lock the caster wheels.
    - ii. One leg should be running vertically up from the floor and two legs should be running horizontal to the floor.
  - d. Place one person on both sides of the fan yoke, to raise the fan up onto the stand.
  - e. Place one person at the bottom of the stand to help guide the vertical leg until it is horizontal to the floor (caster is on the floor). Once the unit is upright this person should stand on the leg while another person lowers the fourth leg until it locks into place.



- f. At this point your SSA should be mounted upright on all four legs of the support stand.
5. Install connecting rod from crank arm to fan motor support assembly. (See page #24)
6. Install the fan inlet guard.
  - a. Remove the three bolts from the back of the fan motor.
  - b. Place the guard against the fan motor such that the three support brackets line up with the three fan bolts.
  - c. Re-install the three fan bolts through the fan guard brackets.
7. Install the control panel stand on one leg as close to the pneumatic support lift as possible.
  - a. Install the control panel cross support bar in the end of the support stand.
  - b. Secure the stand to the leg with two bolts and wing nuts.
8. Install the control panel on the support stand.
  - a. Mount control panel on support stand with two screws in support bar
  - b. Connect the 11ft electrical power cable from the control panel to the SSA fan with the four conductor twist lock plug.
  - c. Connect the (3ft) ¼" poly tubing from the control panel to the base of the pneumatic lift.
9. Fill each of the (4) stability sand bags with 25lbs of sand each.
  - a. Place the sand bags on the outer most part of each leg.
  - b. Lock all caster wheels.



### **START UP AND CHECK OUT**

1. Place all switches in the control panel in the OFF position.
  - a. Rotate the fan speed potentiometer (mounted on the fan VFD speed controller mounted to the fan yoke) to minimum speed. (see p.15)
2. Connect the power cord to any 115v/1ph/60hz outlet receptacle.
  - a. Turn the ROTATE switch to the ON position.
    - i. The fan should start to oscillate and rotate.
    - ii. Turn the ROTATE switch to the OFF position.
  - b. Turn the FAN switch to the ON position.
    - i. The fan motor will start slowly and ramp up to 30% speed.
    - ii. Rotate the fan speed up to 100% and the fan should slowly increase to full speed.
    - iii. Rotate the fan to minimum speed and it should slowly decrease to 30% speed. (Minimum speed of fan is 30%).
    - iv. Turn the fan switch to OFF and the fan should stop.
3. Connect 90 psi plant air to control panel with ¼" quick connect fitting.
  - a. Rotate the LIFT switch clockwise until the lift starts to rise. Raise lift to maximum height for your building. **(make certain the power cable is free to extend as the lift rises)**



- b. Rotate the LIFT switch counter clockwise to the center position when the fan is at the maximum safe height.
  - i. Make sure the fan shroud will not hit any fixed object (roof, steel, pipe, duct, etc.) when it oscillates and rotates.
- c. Rotate the LIFT switch counter clockwise until the lift starts to lower. Lower the stand until the lift is completely lowered.
- d. Raise fan again to maximum height and turn ON the ROTATE and FAN motors.
- e. Turn OFF the ROTATE and FAN motors and lower the fan to fully down position.

### **OPERATION AND USAGE**

You can now move your SSA to any location you want to use it for cleaning or air movement for cooling or destratification. Once you have rolled your SSA to the desired location you will need to lock all casters and place the stability sand bags on each leg.

***Care needs to be taken to make sure no carts or other equipment accidentally runs into the SSA stand. Use portable caution barriers if required for safety.***

***Only move SSA when it is fully down and it is disconnected from the 115v power and plant compressed air. The 25ft cord needs to be rolled up and mounted on support arm of control panel support stand.***

Once you have your SSA in the desired location then use the following steps.

1. Lock all (4) caster wheels to prevent stand from moving.
2. Turn all switches OFF.
3. Place stability bags on all (4) legs to prevent movement and tilting.
4. Place Caution barriers in place if required.
  - a. This is particularly necessary if SSA is located in a traffic area.
5. Plug in 115v cord and connect to plant compressed air hose or portable compressed air tank.
6. Raise fan to desired height.
  - a. Determine the optimum fan elevation to obtain proper cleaning of objects in the overhead area, such as tops of ductwork, pipes, lights, hangers, beams, etc.
7. Turn FAN switch to ON or set it to AUTO for running from the time clock.
8. Turn ROTATE switch to ON or set it to AUTO for running from time clock.
  - a. For certain applications you may want to leave the ROTATE switch OFF.

Fan will now run and clean or cool or destratify until you or the clock turn it OFF.



*CAUTION: Be certain that the fan will be able to rotate a full 360 degrees without hitting any object in the overhead area. CAUTION: Do not locate near any humidifier or adiabatic cooler which produces free moisture (water) which can get on the fan.*

The SSA will come from the factory set to maximum oscillation (from 70 degrees above horizontal to 60 degrees below horizontal). If you want your SSA fan to oscillate through a different range then you will need to adjust the length of the adjustable connecting rod and the position attached in the extended crank arm as shown on pages. See instructions elsewhere in this manual on pages 21 thru 24.

*CAUTION: Be careful not to make the connecting rod too long or too short or you will cause the gearmotor to fail. Warrantee does not cover failures caused by owner installing a connecting rod which is too long or too short. Call IES if you have any questions about the length and connection position in the crank arm.*

### **OPERATIONS INSTRUCTIONS**

The SSA is designed to rotate continuously through a full 360 degree circle. At the same time the fan is rotating it will oscillate the direction of the fan discharge through the angle you choose (the factory set angle is from 60 degrees below horizontal to 70 degrees above horizontal). Because the oscillation of the discharge and the rotation of the fan are not synchronized, the SSA fan is directing air at a different angle from the horizon each time it passes through a complete 360 degrees of rotation (approximately every 10 minutes). This design assures that all of the overhead structures and equipment are thoroughly cleaned.

The effective cleaning radius of the SSA fan is approximately 45 feet from the mounting position, depending upon the obstructions in the ceiling.

### **ELECTRICAL**

The SSA (full load amps) FLA is 7amps @ 115v/1ph/60hz.

### **MAINTENANCE**

All bearings are self lubricated and require no additional lubrication.

Check all electrical connections for proper tightness once per year. A thermal gun should also be used to determine if any electrical component is operating at a higher temperature than it is rated and is safe.

It is recommended that every six to twelve months the SSA fan be visually inspected. At the same time check for all fasteners (bolts, nuts and screws) to be tight and for any oil leakage from the gearmotor. Tighten all bolts, nuts and screws as required. Any other item you



observe that you determine is unusual or questionable; you should call IES immediately for assistance.

### **PARTS FOR SuperSonicAire**

The SSA is an extremely reliable and durable piece of equipment. It should run for many years without any requirement for replacement parts. However in due time when the occasion comes that you need a replacement part we have provided four (4) illustration drawings which identify the key parts with part numbers. If you have any questions about trouble shooting or repairing your SSA, then IES will assist you over the telephone. With digital photographs, emails and the telephone we should have no problem assisting you in troubleshooting your problem.

The SSA comes with a 1 year parts only warrantee. The warrantee begins one month after the unit is shipped to the customer. This should give sufficient time for transportation and assembly. Any misapplication, abuse or improper installation by the owner or his subcontractor will void the warrantee.

*WARNING: If the owner changes the angle of oscillation on the SSA he must precisely follow the directions in the owner's manual. A connecting rod length which is too long or too short for a particular hole location on the crank arm will cause the gearmotor to stop rotation. This will cause a permanent failure to the motor or the gears. Such a failure is not covered by the warrantee.*

*ATTENTION: When the SSA is received from the trucking company, it is the owner's responsibility to inspect the outside of the box for signs of abuse and possible damage. The owner should also open the top of each box to visually inspect for any obvious damage in transit. The owner must record the incident on the receiving slip from the truck driver and then immediately notify IES by telephone and email. The owner usually has **one week** (depending on the carrier) to make an insurance claim with the trucking company for any hidden or latent damages; IES should also be immediately notified by telephone and email of these type of damages.*



TOTAL ASSEMBLY FRONT VIEW

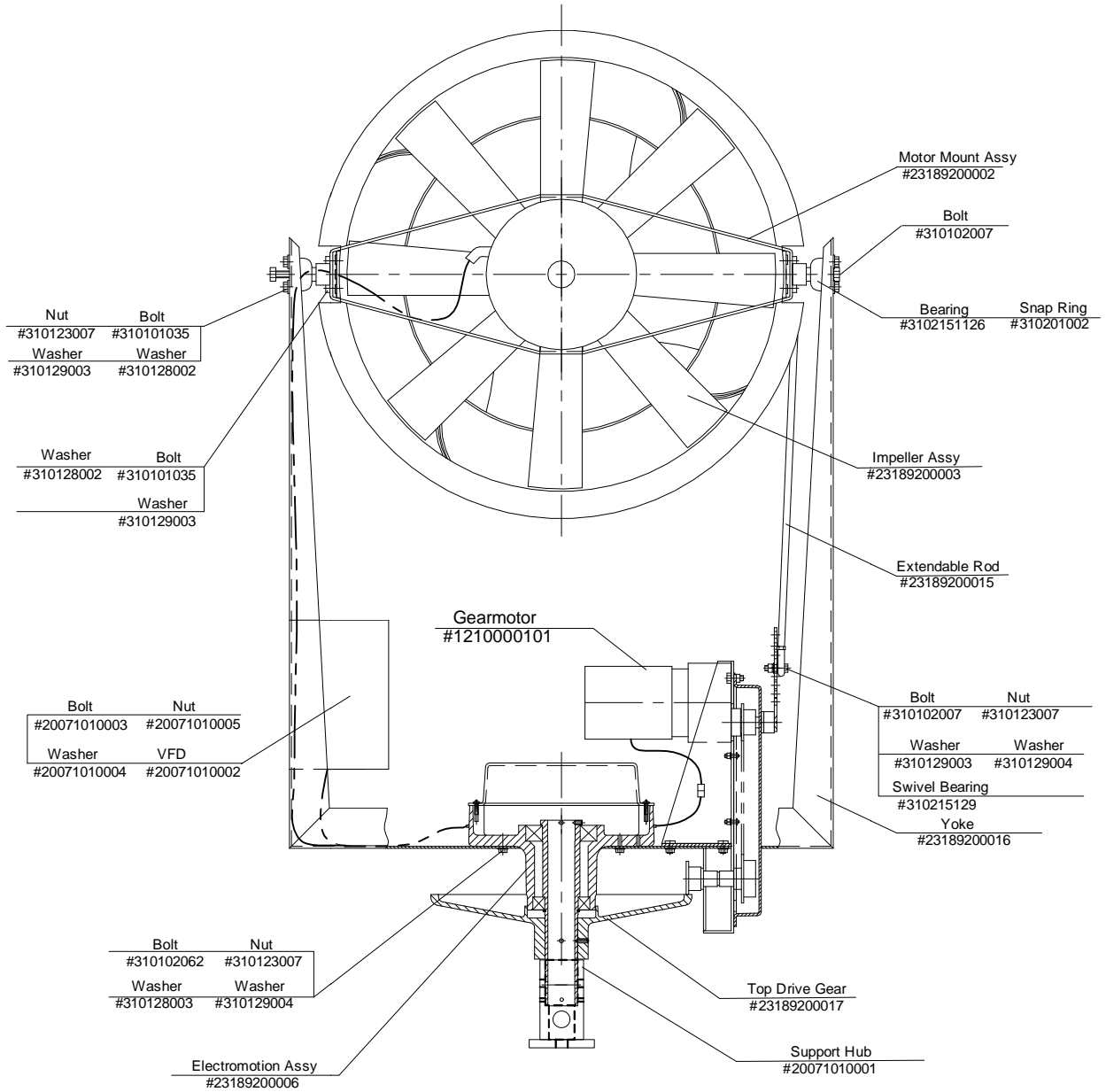



TOTAL ASSEMBLY SIDE VIEW

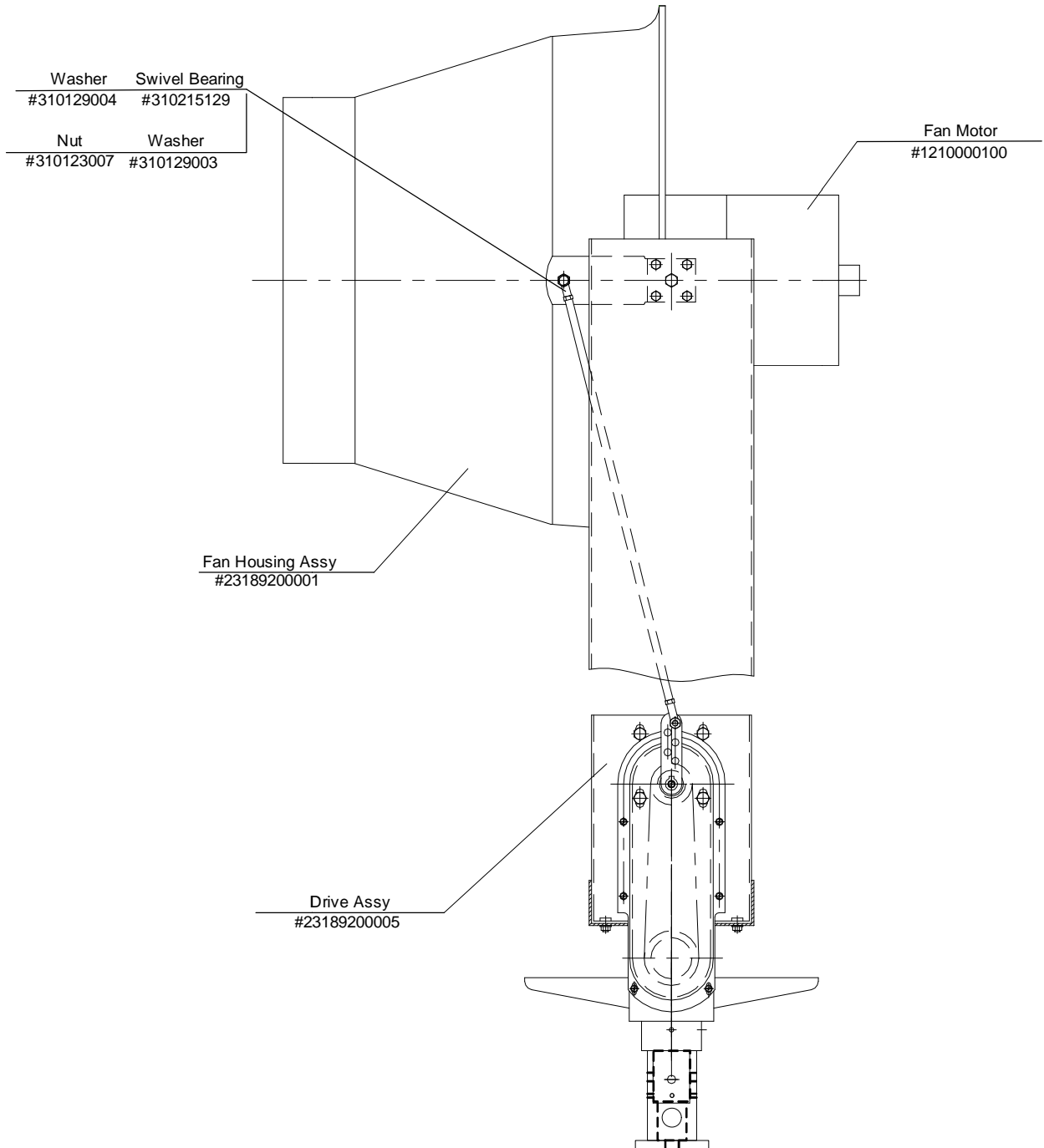

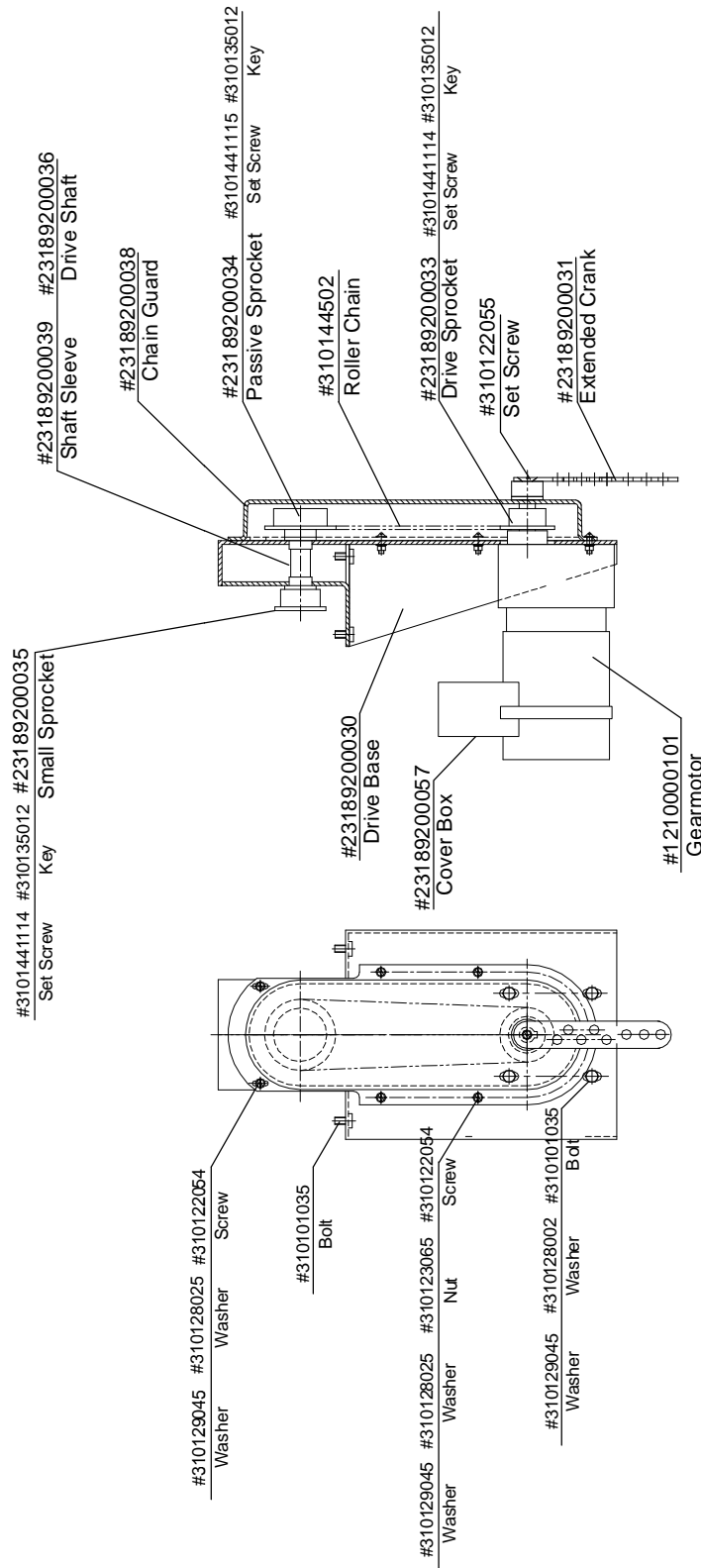

**DRIVE ASSEMBLY**  
**#23189200005**

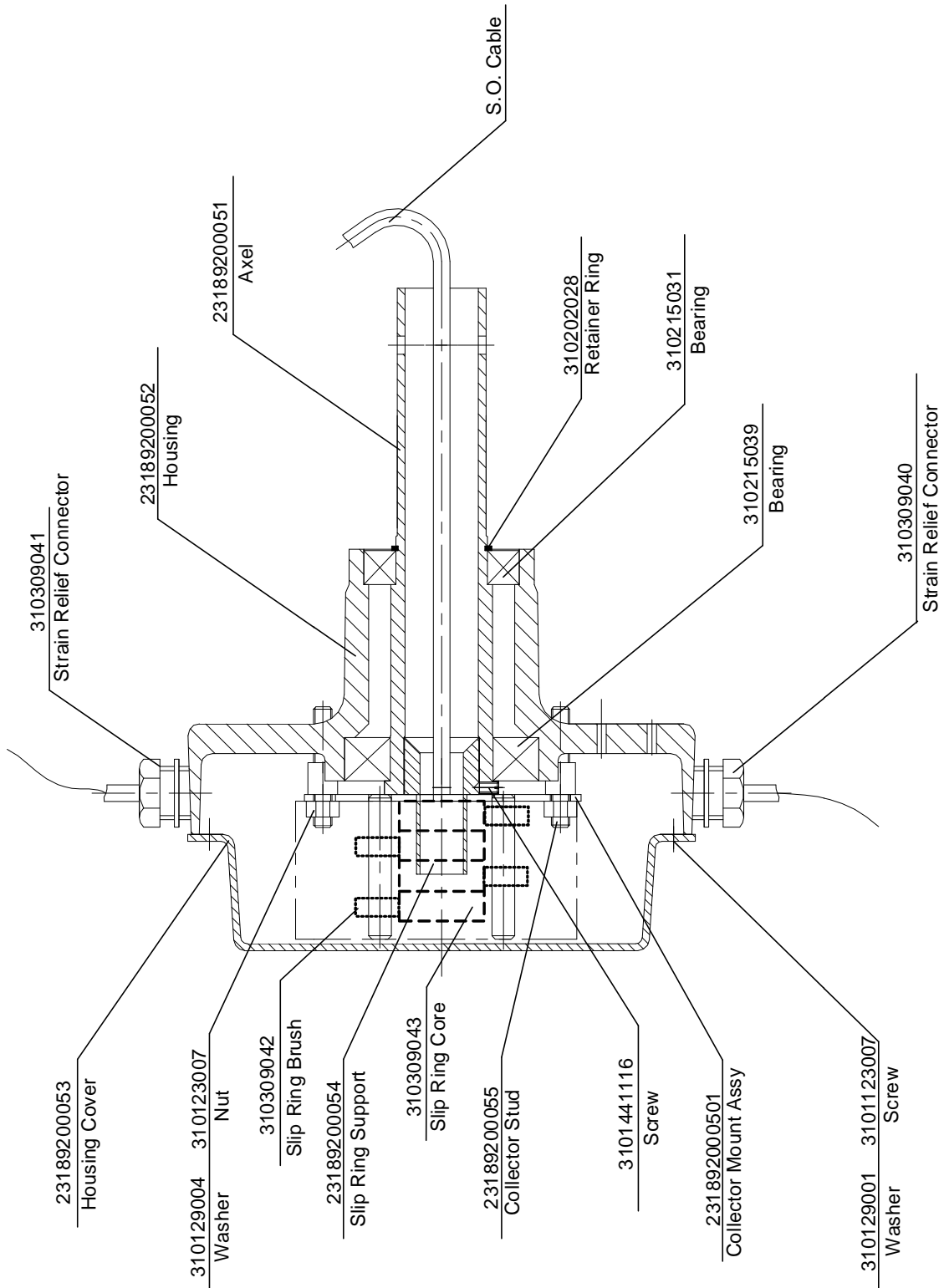

Electromotion Assembly  
23189200006



## CONTROL PANEL FACE

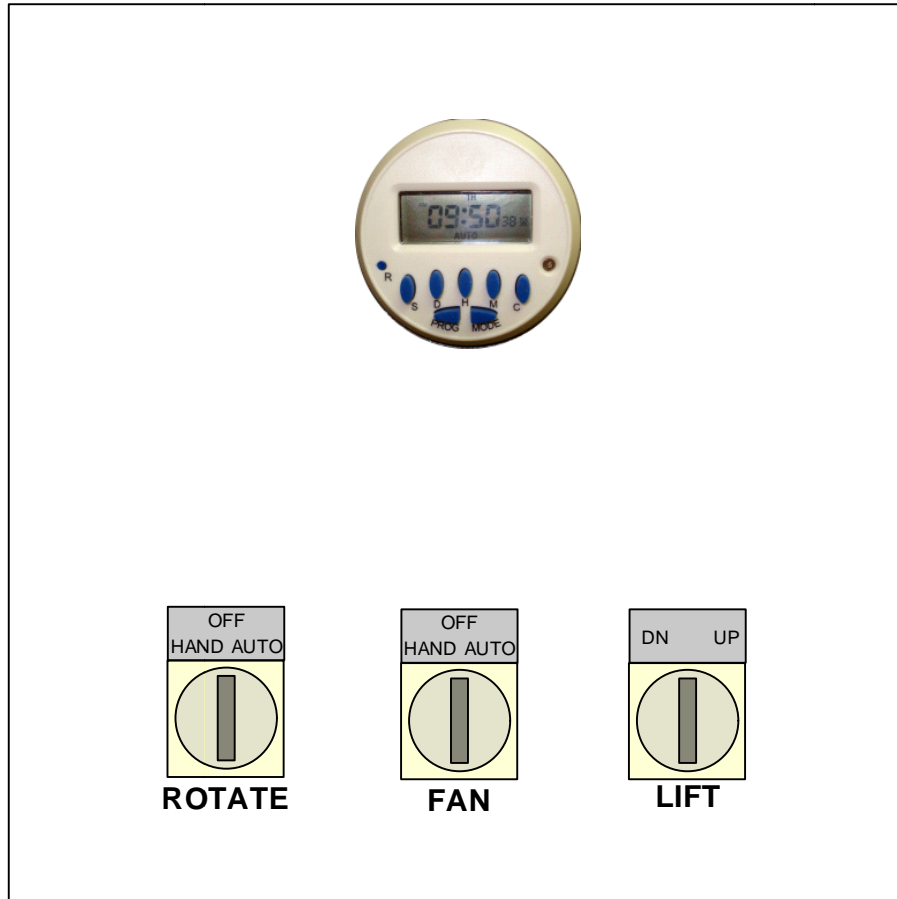

### ROTATE SWITCH

The 'ROTATE' switch turns the gearmotor ON and OFF. When the gearmotor is ON it causes the fan to rotate continuously 360 degrees and to oscillate up and down based on the crank arm position and connecting rod length.

When the 'ROTATE' switch is in the AUTO position it will be controlled by the timer. Whenever the timer is in the ON mode the gearmotor will be energized. This is the typical position when the SSA timer is set to clean your plant at night while the building is unoccupied.

When the 'ROTATE' switch is in the OFF position the gearmotor will not run and the fan discharge position will remain constant in the same direction. This can be used for directing the air to one spot for ventilation cooling, destratification, and etc. The switch should always be in the OFF position when you are moving the SSA or raising and lower the lift.

When the 'ROTATE' switch is in the HAND position the gearmotor will run continuously. This can be used when you want the fan to provide ventilation in every direction or when you want the fan to clean an area besides when the timer is set.



## **FAN SWITCH**

The 'FAN' switch turns the fan motor ON and OFF. When the fan motor is ON it will run at the speed set by the potentiometer on the side of the VFD drive.

When the 'FAN' switch is in the AUTO position it will be controlled by the timer. Whenever the timer is in the ON mode the fan motor will be energized. This is the typical position when the SSA timer is set to clean your plant at night while the building is unoccupied.

When the 'FAN' switch is in the OFF position the fan motor will not run. The switch should always be in the OFF position when you are moving the SSA or raising and lower the lift.

When the 'FAN' switch is in the HAND position the fan motor will run continuously. This can be used when you want the fan to provide ventilation, destratification or cleaning besides when the timer is set.

## **LIFT SWITCH**

The 'LIFT' switch raises and lowers the pneumatic lift. The switch will supply air to the pneumatic lift to cause it to rise and it will bleed air from the pneumatic lift to cause it to lower. In the center position it will keep the lift at a constant elevation.

When the 'LIFT' switch is in the UP position it will supply compressed to the lift and cause it to rise. Once the fan is at the elevation you desire the switch needs to be placed in the center position (the neutral position).

When the 'LIFT' switch is in the CENTER or NEUTRAL position (pointed straight up) then the air in the lift remains constant. (Note: over time the small leakage in the lift seals will cause the lift to slowly lower. This can be several feet over a day)

When the 'LIFT' switch is in the DN position the lift will lower. The lift should always be fully lowered and the LIFT switch should be in the DN or center position when you are moving the SSA. When power is removed from the control panel (power cord unplugged) the air in the lift is completely exhausted causing the lift to completely lower.

## **POTENTIOMETER**

The speed switch is located on the side of the VFD drive which is located on the fan support yoke. The switch uses a potentiometer to provide a signal to the VFD to vary the fan speed from 100% (60Hz) down to 30%. The control range is from '0' to '9'. The position indicates the percent of full speed. When the indicator shows '3' the speed is '3/9' of full speed or 33% (20Hz). Full speed is when the knob is fully rotated clockwise to the '9' position. The read out screen on the VFD will read 60 'Hz' at full speed.





## Dimensional Data

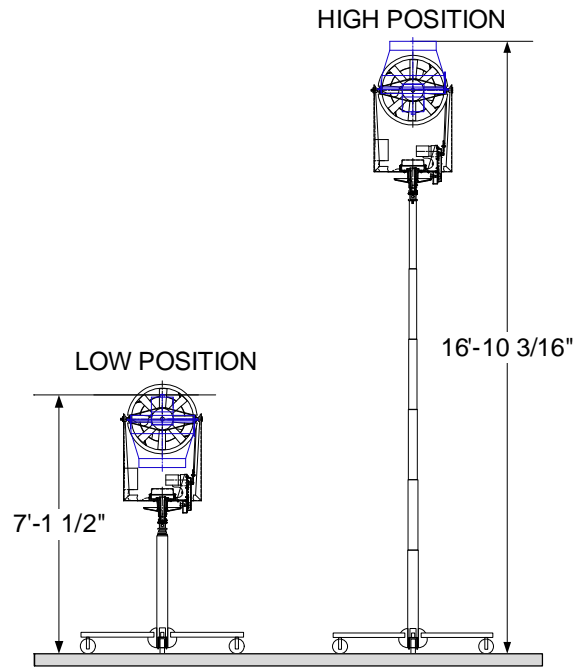

### MIN AND MAX ELEVATION

### PLAN VIEW DIMENSIONS



## PROGRAMMING TIMER

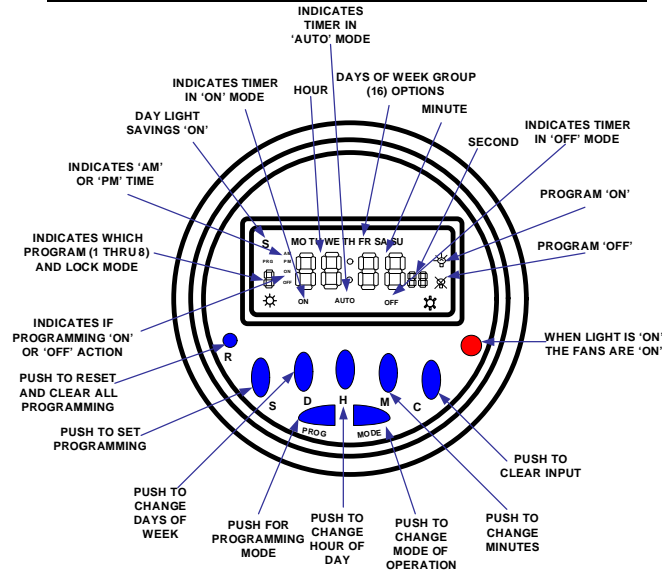

### SUMMARY:

The ACT programmable electronic timer has a micro-processor as a core element to automatically switch ON/OFF your SonicAire fans. In case of a power failure a nickel-hydrogen battery backup will keep your programming for up to 9 months.

### TECHNICAL SPECIFICATIONS:

Voltage: 110v/1ph/60hz

Relay: NC SPST rated for 10 amps resistive

Operating Environment: -4Fdb (-20C) to 150Fdb (65C)

Time Accuracy: +/- (1) second per day

### MODE:

The output switch may be set to one of three different modes; they are 'ON', 'AUTO' and 'OFF'. By pressing on the 'MODE' button you will toggle through the three options. The clock will operate in the mode you leave it in. If you toggle to the 'ON' mode and then to the 'AUTO' mode and leave it in the 'AUTO' mode, then it will remain 'ON' until the next programmed 'OFF' time. If you toggle to the 'OFF' mode and then to the 'AUTO' mode and leave it in the 'AUTO' mode, then it will remain 'OFF' until the next programmed 'ON' time.

### RELAY POSITION:

When the clock is in the 'ON' mode the output SPST relay will be closed. When the clock is in the 'OFF' mode the SPST relay will be open. A red light on the face of the display will be ON when the relay output is closed and OFF when the relay output is open.

RESET BUTTON: The small blue recessed button on the left side of the display with the letter 'R' below it may be pressed with a pen to clear all programming and reset the micro-processor memory.

## SETTING CLOCK TIME AND DAY



**DAY:** The day of week may be set by simultaneously pressing the 'S' set button and the 'D' day button. Continue to toggle the 'D' button until you get to correct day of the week then release both buttons.

**HOUR:** The hour of the day may be set by simultaneously pressing the 'S' set button and the 'H' hour button. Continue to toggle the 'H' button until you get to correct hour then release both buttons.

**MINUTE:** The minute of the hour may be set by simultaneously pressing the 'S' set button and the 'M' minute button. Continue to toggle the 'M' minute button until you get to correct minute then release both buttons.

**12/24 HOUR CLOCK:** The clock may be set to show military time (24 hour clock) or standard AM and PM 12 hour clock. To change from a 24 hour to a 12 hour clock simultaneously press the 'S' set and the 'PROG' program buttons simultaneously. When you get to the type of hourly display you want to see release both buttons.

**DAYLIGHT SAVINGS TIME:** The clock may be changed from/to day light savings by simultaneously press the 'S' set button and the 'MODE' mode button. When you get to the type of day you want release both buttons.

**LOCKING PROGRAMMING:** You can lock out others from all programming by pressing the 'S' set key and 'C' clear key at the same time for over three (3) seconds. The screen will display the 'a' character on the left side when the programming is locked. You can unlock the programming by pressing the 'S' set key and the 'C' clear key at the same time for over three (3) seconds.

## **PROGRAMMING ON/OFF ACTIONS**

**SCHEDULES:** There are (8) eight ON schedules and (8) eight OFF schedules which can be programmed. Normally only one schedule will be used and it will turn the SonicAire fans ON at the same time and OFF at the same time each day of the week. Usually owners will run their SonicAire fans for one or two hours per day during the night when their plant is not occupied (such as from 1:00 am to 3:00 am). To program a schedule you press the program 'PROG' button. The first time you press the button the screen will display **1<sup>on</sup>**. When you press the 'PROG' button again the screen will display **1off**. As you continue to press the 'PROG' button you will sequentially go through all eight ON and eight OFF schedules as shown: {**1<sup>on</sup>, 1off, 2<sup>on</sup>, 2off, 3<sup>on</sup>, 3off, 4<sup>on</sup>, 4off, 5<sup>on</sup>, 5off, 6<sup>on</sup>, 6off, 7<sup>on</sup>, 7off, 8<sup>on</sup>, 8off**}  
**Stop pressing the 'PROG' button when you get to the schedule you want to program.**

**DAYS OF THE WEEK GROUPS:** While the display shows the schedule you want to program (such as **1<sup>on</sup>**) you will next program the group of days in the week you want your SonicAire fans to turn ON or OFF.



As you sequentially press the day 'D' group button the display will show sixteen (16) different type of day groups. The groups are in the sequence as shown below:

Group 1: (Mo, Tu, We, Th, Fr, Sa, Su) *All days of the week.*

Group 2: (Mo)

Group 3: (Tu)

Group 4: (We)

Group 5: (Th)

Group 6: (Fr)

Group 7: (Sa)

Group 8: (Su)

Group 9: (Mo, Tu, We, Th, Fr) *5 day work week.*

Group 10: (Mo, Tu, We, Th, Fr, Sa) *6 day work week.*

Group 11: (Sa, Su) *2 day weekend.*

Group 12: (Mo, We, Fr)

Group 13: (Tu, Th, Sa)

Group 14: (Mo, Tu, We)

Group 15: (Th, Fr, Sa)

Group 16: (Mo, We, Fr, Su)

**Stop pressing the 'D' day button when you get to the group of days you want to program.**

**HOUR OF THE DAY:** Next you program the hour of the day you want your SonicAire fans to turn ON or OFF by pressing the 'H' hour button. As you sequentially press the 'H' hour button the time of day will go up by one (1) hour. [Note: You may use either a 24 hour clock display or a 12 hour (am/pm) display; see 12/24 HOUR CLOCK above.]

**Stop pressing the 'H' hour button when you get to the hour of the hour you want to program.**

**MINUTE OF THE HOUR:** Next you program the minute of the hour you want your SonicAire fans to turn ON or OFF by pressing the 'M' minute button. As you sequentially press the 'M' minute button the minute of the hour will go up by one (1) minute per press. [Note: If you hold the 'M' minute button down it will start to rapidly advance the minutes until you release the button.]

**Stop pressing the 'M' minute button when you get to the hour of the minute you want to program.**

**CLEARING A SCHEDULE:** You can clear a schedule if you press the 'C' clear button while in the programming mode and the display shows the schedule {1<sup>on</sup>, 1<sup>off</sup>, etc.} you want to clear.

**SETTING A SCHEDULE:** Once you have programmed all the scheduled times during the week that you want to turn your SonicAire fans ON and OFF you can set the schedule and exit the programming mode by pressing the 'S' set button. {Note: If you stop pressing programming buttons for over 15 seconds the micro-processor will automatically set all of the programming you have done and exit from the programming mode}



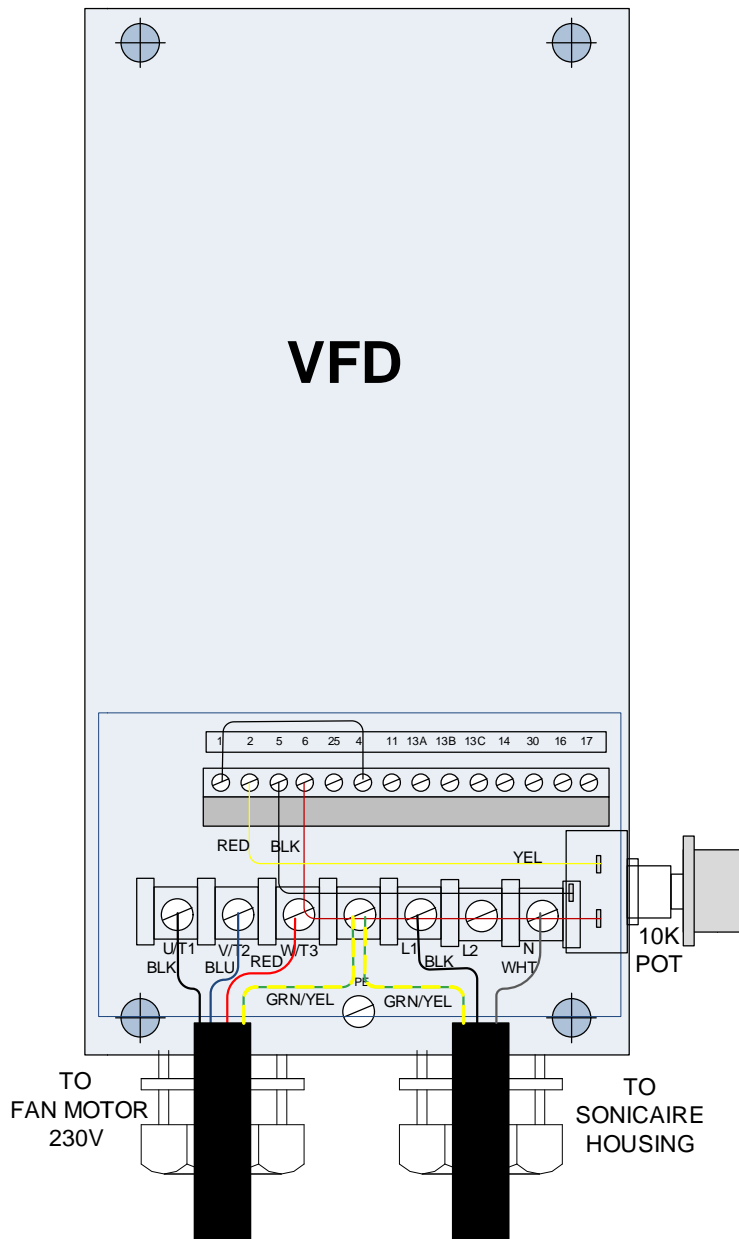















## **VFD WIRING LAYOUT**



**Caution: VFD capacitor will remain charged for a period of time after power is removed. Do not work on VFD until LED screen display goes off.**

## **VFD PROGRAMMING**



<b>VFD Programming Action Steps</b>	
<b>Step</b>	<b>Action</b>
1	Assure there is a jumper between terminals #1 and #4 (this allows the fan to run on power up)
2	Power VFD by turning 'FAN' switch 'ON' at control panel. Control panel must be plugged into 115v wall socket with three conductor male plug and to the fan with four conductor female twist-lock plug
3	Press enter key  the word "PASS" should appear on screen which is short for "PASSWORD"
4	Press up/dn  keys "UP" until the display reads "0225" Entering this password number allows you to program VFD
5	Press enter key  (Now you can program or set the parameters specific to how you want to run the VFD)
6	Press up/dn  keys until the display reads "P100" The screen should come up "P100" initially and therefore would not require pressing the up/dn keys.
7	Press enter key 
8	Press up/dn  keys until the display reads "1"
9	Press enter key  (allows jumper #1 to #4 to automatically start fan on power up)
10	Press up/dn  keys 'UP' until the display reads "P101"
11	Press enter key 
12	Press up/dn  keys until the display reads "1"
13	Press enter key  (allows "POT" to control fan speed)
14	Press up/dn  keys 'UP' until the display reads "102"
15	Press enter key 
16	Press up/dn  keys until the display reads "20"
17	Press enter key  (This sets minimum fan speed at 20hz or 33% which is minimum speed fan motor should run)
18	Press up/dn  keys 'UP' until the display reads "110"
19	Press enter key 
20	Press up/dn  keys until the display reads "3"
21	Press enter key  (This causes fan to automatically START when VFD has powered input )
22	Turn off power to VFD by turning 'FAN' switch to 'OFF' position. Leave off until VFD display screen goes 'OFF'.
23	Turn 'FAN' switch to 'ON' position and fan should automatically start and run at speed set by 'POT'

**CHANGING THE OSCILLATION ANGLE OF THE SuperSonicAire FAN**



When changing the oscillation angle in the field the owner must be careful not to adjust the connecting rod too long or too short for the particular hole the rod is connected to in the crank arm. See page 20 for the minimum and maximum lengths of connecting centerline distances for each of the eight (8) crank arm positions. If the connecting rod is too long or too short it will cause the gearmotor to be in a bind which will either burn out the motor or strip the gears. Warrantee does not cover misadjusting the connecting rod. You may contact IES to confirm your selection of rod length and crank arm position for a certain angle of oscillation.

The owner must first decide the maximum upper angle required and the lower angle required which will provide the performance and cleaning desired. Because there are only eight (8) fixed radiuses in the crank arm, you will need to decide if the upper or lower angle is most critical.

Using the chart on page 19, draw a straight line across the graph at the desired upper angle. The upper slanted lines for the same crank arm position show the length of rod required, in each of the eight crank arm positions, to achieve the desired upper angle. Your line may pass through several upper lines for the various positions on the crank arm. Next you draw a line down from where it intersects the upper slanted line until it crosses through the lower slanted line of the same crank arm position. Next you draw a straight line back to the axis on the chart which gives the angle of the fan discharge. This angle will be the corresponding lower angle for the given connecting rod length in the given crank arm position. If the lower angle is not what you want, then you can do the same for the other slanted lines which your upper desired angle of oscillation passes through. Select the connecting rod length and crank arm position which gives you the upper and lower angles closest to what you desire.

If the lower angle is more critical than the upper angle then you will start by drawing a straight line across the graph showing all of the intersection points with the lower slanted lines at the desired lower angle. Next you will draw a line up from each lower slanted line to the upper slanted line of the same crank arm position, this will show you the corresponding upper angle for a given rod length and crank arm positions which gives you the desired lower angle. Select the rod length and crank arm position which gives you the upper and lower angles closest to what you desire.

You may call IES to assist you in your selection if you are not sure about your own selection or simply want a confirmation of your selection process.

When adjusting the centerline distance of your connecting rod it should be removed from the fan support arm and the crank arm. Lay the rod with both self aligning swivel bearings on a flat surface. Adjust the connect rod length until the centerline to centerline of the two bearings is what you want. Secure the rod length with the two set nuts on the rod. Do not change the distance the connecting rod is screwed inside each swivel bearing, when mounting the connecting rod to the crank arm and fan support arm.

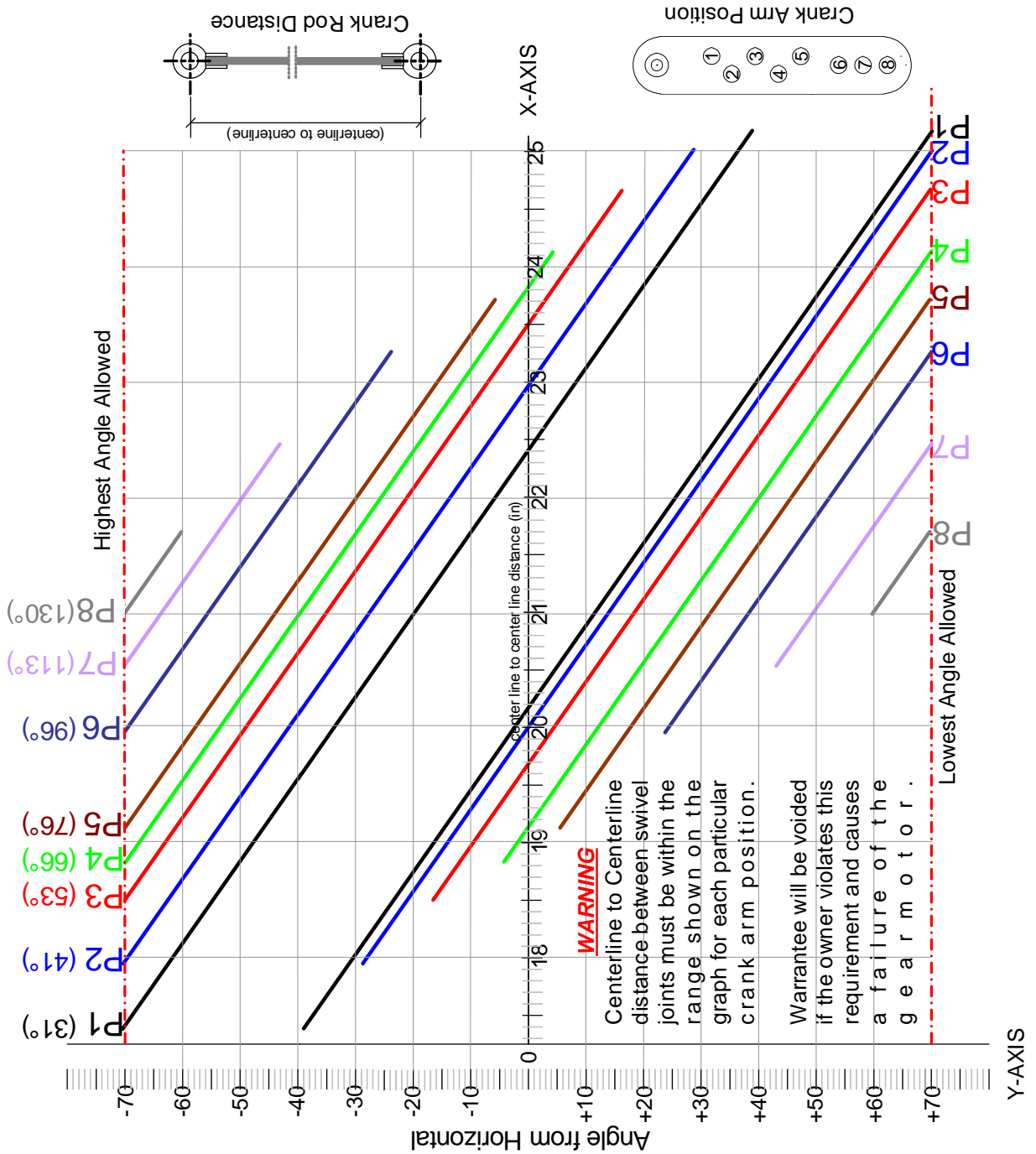

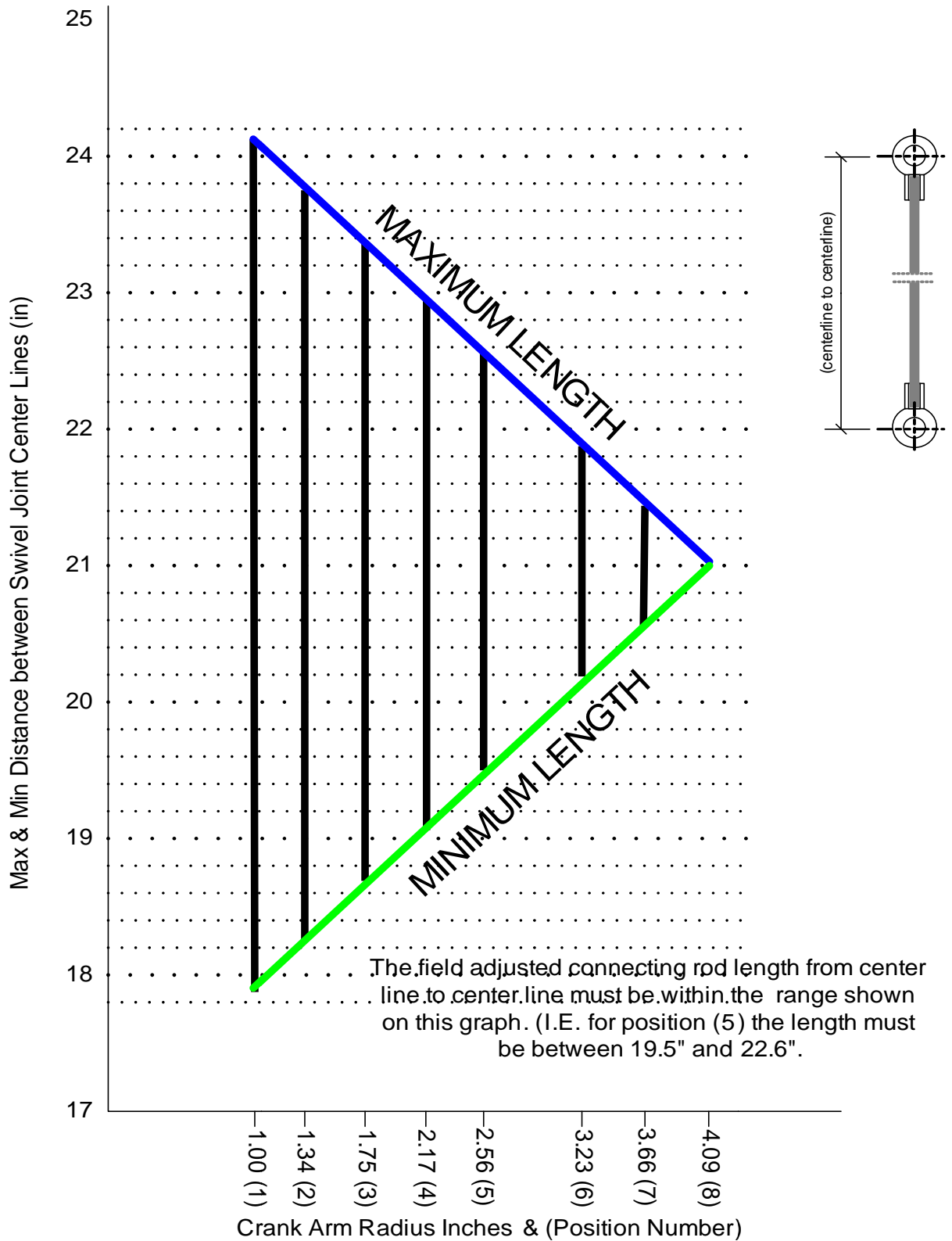



**EXTENDED SETTING**

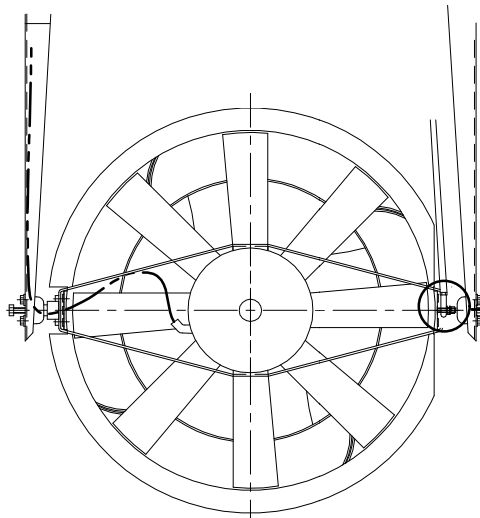
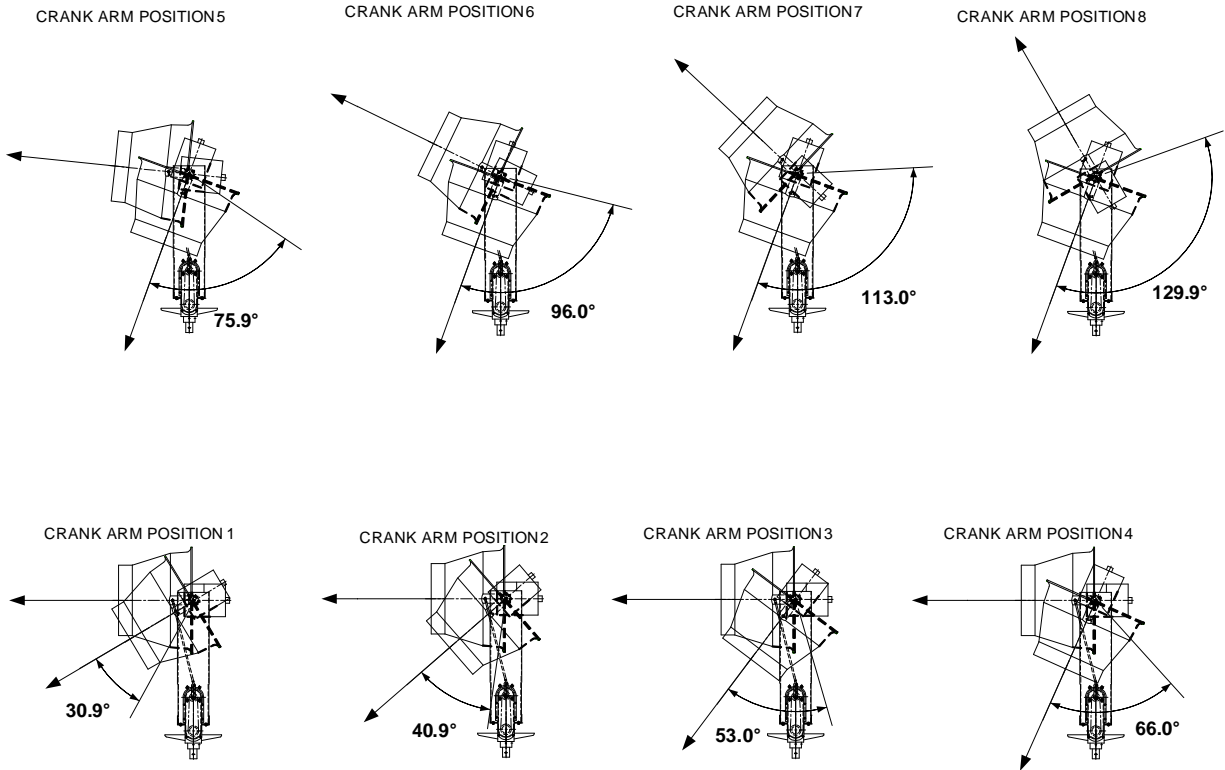

When attaching connector rod swivel to fan support arm :  
1. First slip the swivel joint on the bolt stud.  
2. Next slip on 8mm lock washer.  
3. Last tighten 8mm cap nut fully against lock washer .

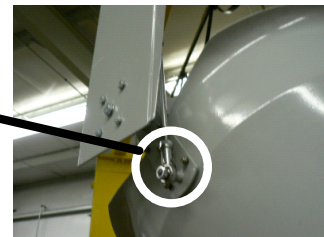
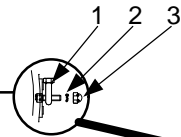

**FASTENING ADJUSTABLE CONNECTION ROD TO FAN SUPPORT ARM**





# CONTROL PANEL ELECTRICAL & PNEUMATIC LAYOUT

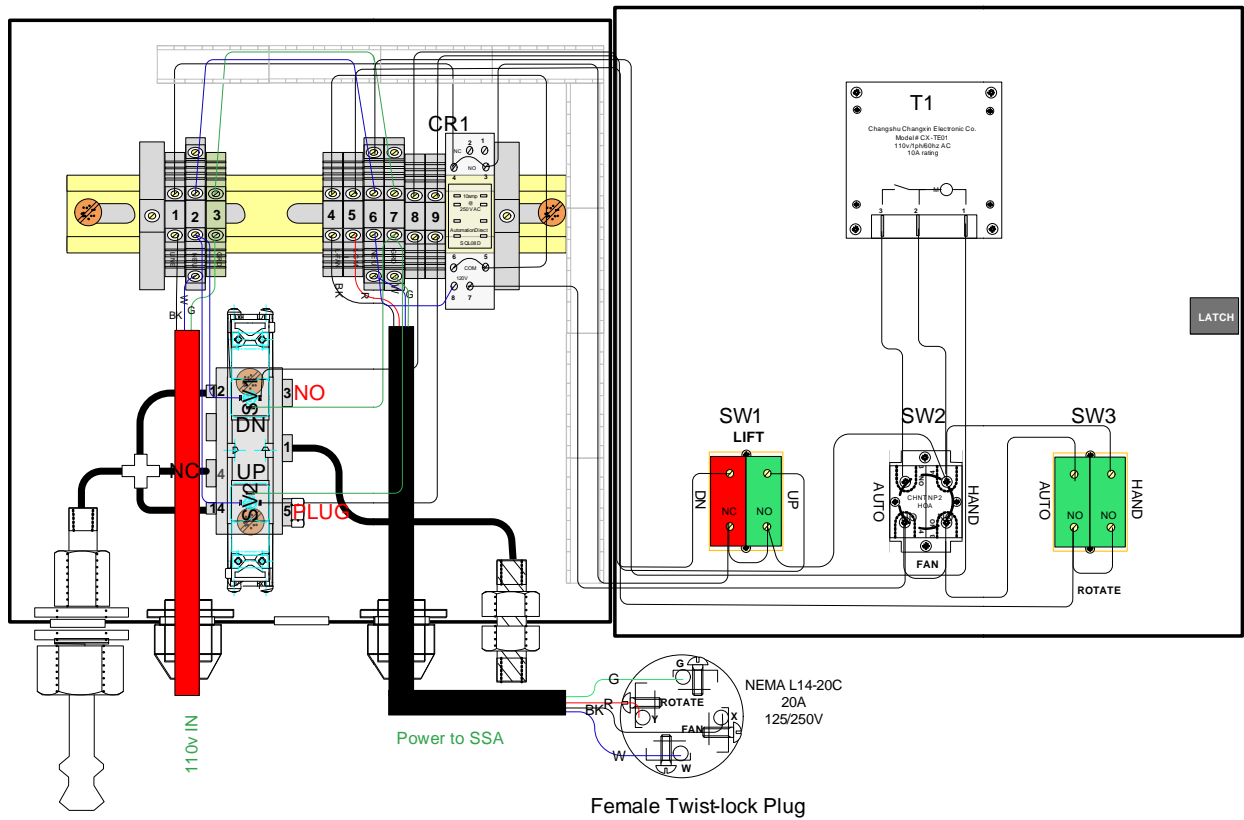



# SLIP-RING HOUSING WIRING LAYOUT

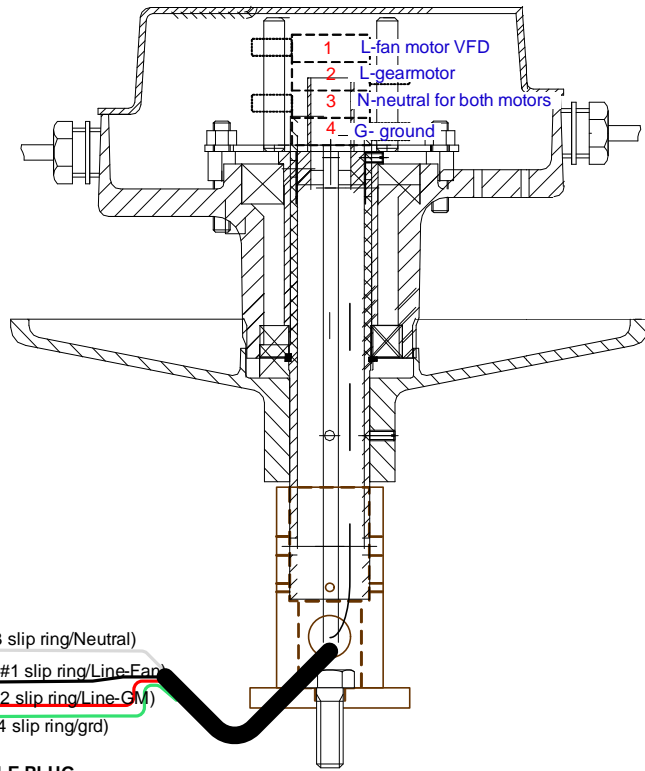
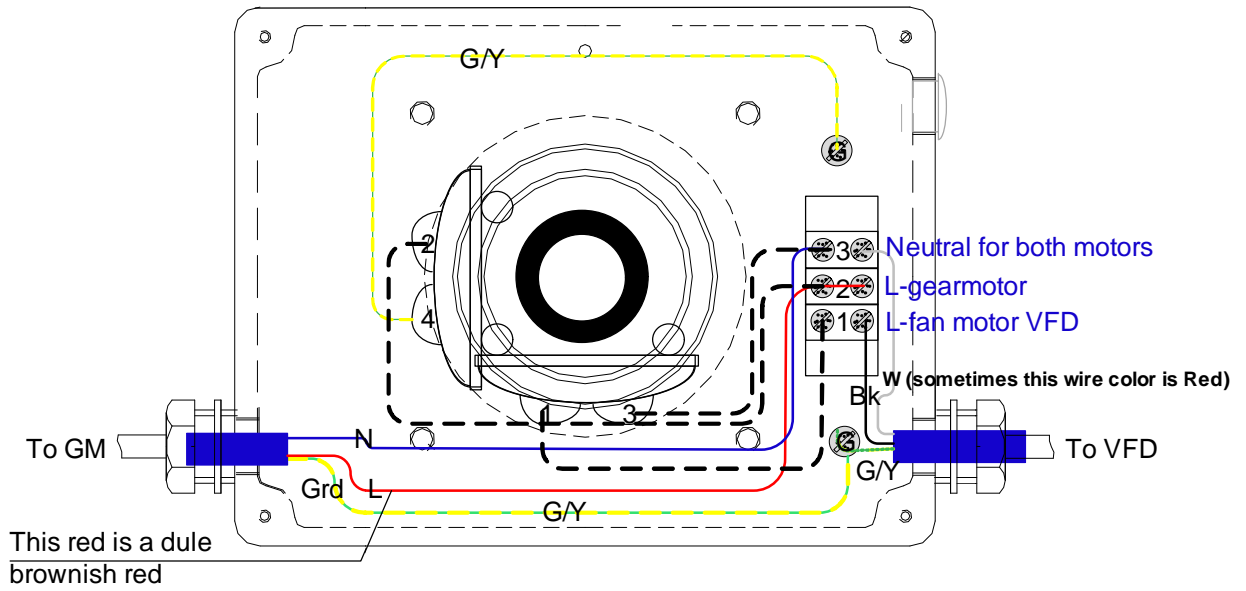

NEMA L14-20C  
20A  
125/250V



## OPTIONS

### **Lint Filter:**

The SuperSonicAire fan can be fitted with a filter media to capture lint generated near ironing and folding equipment during plant operation. Capturing a high percentage of free lint in the air will minimize cross contamination of free lint in the air.



### **Longer power cord:**

Longer plug in cord (standard cord is 25ft): 50ft cord or 100ft cord.

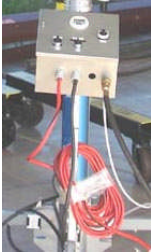

### **Stability Sandbag;**

25 lb saddle bag type weight for each support leg for added stability to SSA during operation at extended elevations. Bag comes without sand ballast and is easily filled with a zipper on both sides of the saddle style weight. (note: standard SSA comes standard with (4) stability bags.)



### **Compressed air tank:**

Five gallon compressed air tank with leg mounted bracket, pressure gage, quick connect fittings.





**Integrated  
Environmental  
Solutions**



**Integrated Environmental Solutions**  
3143 S. Stratford Rd., Ste 5  
Winston-Salem, NC 27103  
Ph: (336) 712-2437  
Fax: 810-454-0452  
Email: [sales@iesclean.com](mailto:sales@iesclean.com)  
[iesclean.com](http://iesclean.com)